

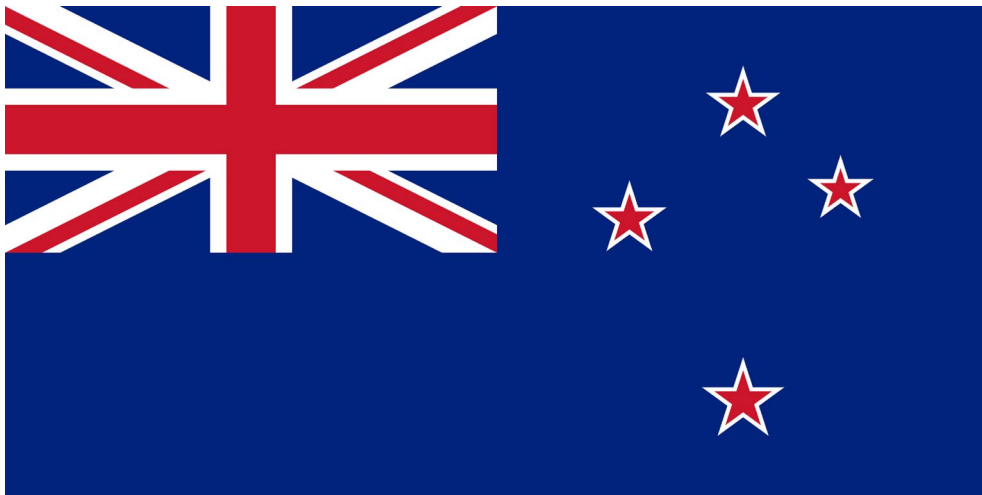

The Leon Morel Catalogue of Medallic Commemoratives of New Zealand up to 1940:

1939-1940 Centennial and Centennial Exhibition



Chapter Editors: Martin Purdy, Jason Gray, Rodney Hall, and Hamish MacMaster

RNSNZ © 2020 - 2022

Version 1. Last Updated: 2022-Jan-29

ISBN 978-1-99-116120-8

The Leon Morel Catalogue of Medallic Commemoratives of New Zealand up to 1940:
The Centennial and Centennial Exhibition, 1939-1940

ISBN 978-1-99-116120-8 (digital)

ISBN-978-1-99-116090-4 (print)

Martin Purdy FRNSNZ

Jason Gray

Rodney Hall

Hamish MacMaster FRNSNZ

Copyright © RNSNZ and the contributing editors, 2022

This work is freely distributable in electronic form and is not intended for sale or resale, either electronically or in hard copy. Please acknowledge the RNSNZ when sharing.

Download the latest version from

www.RNSNZ.org.nz/collector-info/catalogues

Royal Numismatic Society of New Zealand Inc.

PO Box 2023

Wellington 6140

New Zealand

Autobiographical Note



Leon with members of the "Starlets" coin club in 1966 (NZ Numismatic Journal no. 42)

My introduction to numismatics was at school when I swapped a box of marbles for WW1 coins. This small group of coins fascinated me and led me to visit the Canterbury Museum's large collection many times.

Fortunately a custodian suggested I contact Ernie Dale who was Chairman of a Society who could help me. He certainly did and I joined the Canterbury Branch of the RNSNZ and enjoyed many years in the company of informative speakers who widened my knowledge. I am forever grateful to the members of the Canterbury society.

The introduction of decimal currency in 1967 resulted in a surge in sales of New Zealand sterling coins at inflated prices, which led me to advertise price lists at what I considered more sensible levels.

New Zealand medallions were plentiful and, in 1950, with the issue of the Canterbury Centennial medal, I started collecting medallions in earnest which eventually led to the issue of a small catalogue in 1976, and later, as new items were found, a much expanded and illustrated second edition (1996) and a supplement (2000).

I also purchased a small, lovely collection of Edward VIII Coronation medallions, which grew into a very large collection. Many friendships resulted, including Richard Lobel of Coincraft, who has an amazing collection.

Autobiographical Note

Banknotes became an interest when I discovered the Reserve Bank of New Zealand would sell notes direct to collectors, a great service which has sadly been discontinued.

We retired to Melbourne, where our four sons resided, in 2000. So I packed my accumulation into 120 special containers which Customs officials were interested in, but released them when they realised it was my private collection.

I am delighted that the team will update “Medallic Commemoratives New Zealand 1865-1940”.

My congratulations and appreciation.

Leon G Morel FRNSNZ (2016)



2006 anniversary event, at which Leon Morel (left) was the longest-standing RNSNZ member (joined 1950) and Ray Staal (right) the longest-standing WCC member present (joined 1966)

Note by the compilers (2020): Leon gave his agreement to our updating his catalogue to include more recent discoveries during his visit to the RNSNZ Convention in 2014. Work began almost immediately on digitising the text of his 1996 Catalogue and 2000 Supplement, as well as logging new discoveries and gathering photos of existing items. This activity has continued in the background ever since, though it has only been with the upheavals to normal work routines brought about by Covid-19 that we have had the opportunity to start putting it into its final shape.

Leon died in late 2019 at the age of 87, and we are saddened not only by the loss of someone who put such a huge effort into documenting and promoting New Zealand commemorative medals, but also by the fact that he did not live to see the release of this, the first instalment of the revised 3rd edition of his magnum opus.

Contents

Autobiographical Note	3
Contents	5
Foreword	7
Introduction.....	9
Acknowledgements.....	11
Bibliography.....	13
Latest Additions	17
Amendments & Updates to 1996/2000 Edition	19
Commemorative Medals – 1939-40 – Centennial Issues.....	21
Commemorative Medals – 1939-40 – Exhibition Issues.....	81
List of Makers & Manufacturers.....	109
Rarity Scale	111
About the Authors	113
Thematic Index	117
Notes / New Additions	119
The End.....	120

Foreword

It is an honour to write the Foreword to this update of the 1940 Centennial and Exhibition commemoratives listed originally in Leon Morel's Catalogue of Medallic Commemoratives of New Zealand, 1865-1940. I commend the new approach to publicising these updates in segments and in electronic form. This will allow the work to be regularly updated as well as the information being readily and freely accessible to all collectors, the primary motivation of its authors.

Morel's work is the bedrock of our study of New Zealand commemorative medals. All subsequent work on this topic is based on the expert foundation that he laid. With regard to the medals of the Centennial, however, Morel was himself disparaging of the 1940 product:



"Of all the commemorative issues during the 1865-1940 period those issued for the New Zealand 1940 Centennial Exhibition overall are the poorest examples of medallic workmanship. The abysmal issues for that historical event are only saved from total denigration by the New Zealand Numismatic Society commemorative 1940/1 and the international Photography Medal 1940/11. Strictly the remainder are cheap souvenirs and I contemplated deleting the majority because of this."

That Morel did not and in fact went on to do the exact the opposite, recording all in some detail, was because *"of the importance of the event. Further there was no record of these pieces. Finally, many were of unusual design and quite interesting."*¹

1940 is without any doubt one of New Zealand's most significant national milestones reflected in medallic commemoratives – up there with the 1897 Queen Victoria's Diamond Jubilee, the 1899-1902 Boer War, 1914-18 World War I, 1953 Royal Visit, 1967 Decimalisation, 1969 Cook Bicentenary and 2000 Millennium. That its commemoratives were by and large of pedestrian quality is perhaps understandable given the strictures of war.

One has only to compare the issue to that of the 50th Anniversary of the Colony medal in 1890 to get a sense of how much the country had developed in its national consciousness by 1940. The absolute profusion of topics on these medals testifies to the growing awareness and pride at what had been achieved, the development of new industries such as photography and the strong indigenous nature of New Zealand multicultural society. What was depicted and how it was depicted reveals much about the state of the country at this time and underlines the importance of these pieces as a historical resource.

¹ Leon G Morel FRNSNZ, Supplement to Medallic Commemoratives of New Zealand 1865-1940, printed 2000, p. 23

Foreword

And let us not forget that the nature of commemoratives themselves was changing exactly at this time. The increasing use of wristwatches meant the 1940s mark the point when medals were transitioning in many cases from being an appendage on people's fob watches to pin-back and clip-on souvenirs or more substantive entities in their own right, such as the 1940 NZNS medal cited by Morel.

In summary I believe the sheer range and profusion of these items should not deter collectors, but instead should be a source of inspiration to build up a comprehensive collection of these interesting historical pieces. In so doing I am confident collectors will find this catalogue an invaluable and comprehensive reference tool.

Hamish MacMaster, FRNSNZ
August 2020

Introduction

The Leon Morel Catalogue of Medallic Commemoratives of New Zealand up to 1940:

The New Zealand Centennial and Centennial Exhibition, 1939-1940

Martin Purdy FRNSNZ
Jason Gray
Rodney Hall
Hamish MacMaster FRNSNZ

ISBN 978-1-99-116120-8

This is the first part of a projected multi-volume series updating Leon Morel's Catalogue of Medallic Commemoratives of New Zealand, 1865-1940 (1996) and the Supplement published in 2000. The third edition marks a departure from previous RNSNZ catalogue projects in that it is being released electronically in the first instance, and in sections. In this way, parts of the book can be published as they become ready, and can also be regularly updated as new information becomes available.

The various sections of the catalogue will ultimately cover the whole of NZ's medallic history from the earliest issues associated with this country through to the Centennial events of 1940. More recent issues, from 1940 (not Centennial-related) to date, will be covered by a companion series, "New Zealand Commemorative Medals since 1940, 3rd edition", also to be published in parts and in electronic form.

Acknowledgements

Special thanks to the late Leon Morel for entrusting us with this project and supplying much original reference material.

Thanks to the many dealers and collectors who have made illustrations available, including Tony Grant, Jim Noble, Jim Johnson, Graeme Hancock, Ross and Angie Kidd, Craig Kitchen, Don MacNeill and many others whom we have approached with specific requests since beginning this project in 2014.

Version no.: 1, January 2022

Bibliography

NZ Medals:

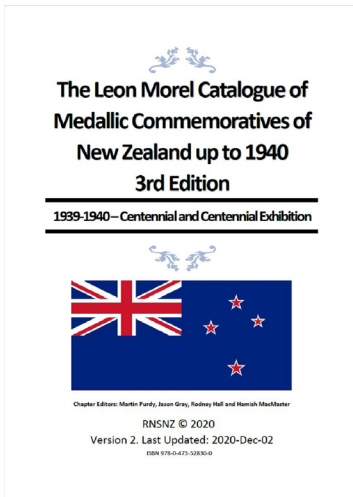

Purdy M, Gray J,
Hall R, MacMaster H

Catalogue of Medallic
Commemoratives of
New Zealand
Up To 1940
(3rd edition)

(PDF Only By Decade)

© RNSNZ 2020-2021

ISBN
978-0-473-52830-0

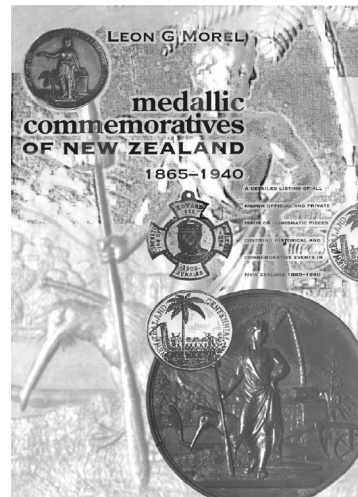

Morel L G

Medallic
Commemorative
of New Zealand
1865-1940
(2nd edition)

© LGM 1996



Morel L G

Medallic
Commemorative
of New Zealand
1865-1940
(Supplement to
2nd edition)

© LGM 2000



Morel L G

Medallic
Commemorative
of New Zealand
1865-1940
(1st edition)

© LGM 1976

Bibliography



Purdy M, Gray J,
Hall R, MacMaster H

New Zealand
Commemorative
Medals Since 1940
(3rd edition)

(PDF Only By Decade)

© RNSNZ 2020-2021

ISBN
978-0-473-54232-0

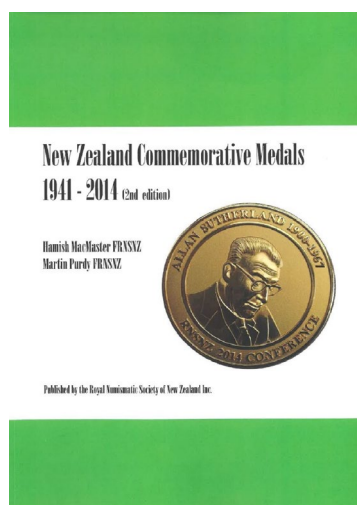

MacMaster H &
Purdy M

New Zealand
Commemorative
Medals 1941-2014
(2nd edition)

© RNSNZ 2014

ISBN
978-0-473-28731-3

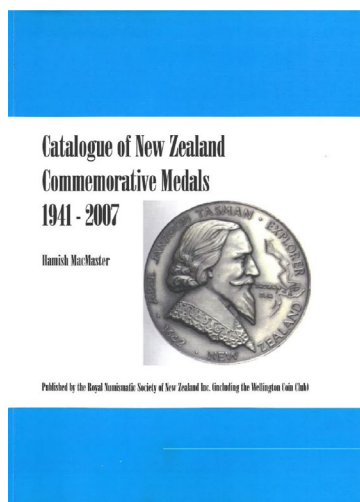

MacMaster H

New Zealand
Commemorative
Medals 1941-2007
(1st edition)

© RNSNZ 2007

ISBN
978-0-473-15585-8

Other NZ:

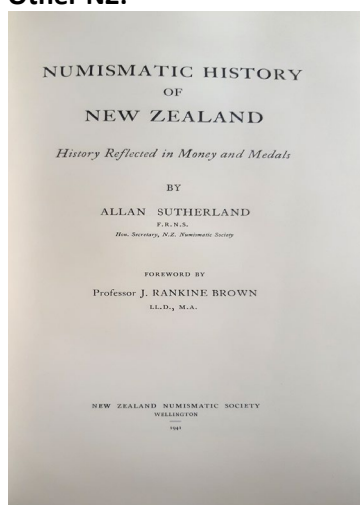

Sutherland A

Numismatic History
of New Zealand

History Reflected in
Money and Medals

© NZNS 1941



Thornton J

The John Bertrand™
New Zealand Coin &
Banknote Catalogue
2021

© John Bertrand 2021

ISBN
978-0-9941337-9-3

Bibliography

International:

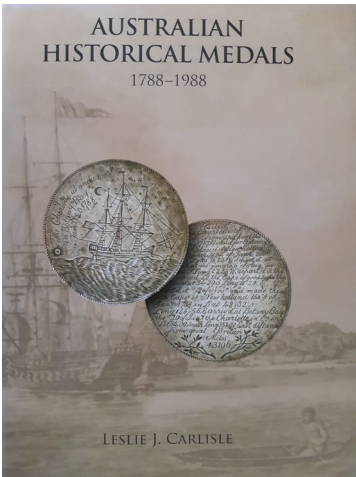

Carlisle L
Australian
Commemorative
Medals 1788-1988

© L.J. Carlisle 2008
ISBN
978-0-98040-615-3

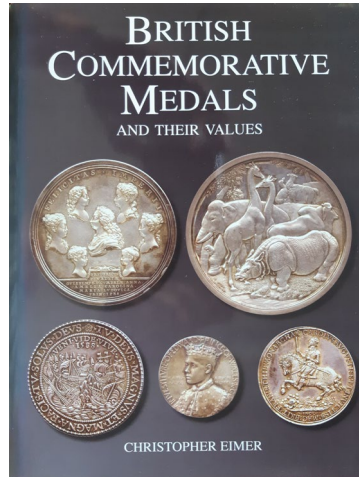

Eimer C
British
Commemorative
Medals and Their
Values

© Christopher Eimer
2010
ISBN
978-1-907427-06-0

Serials:

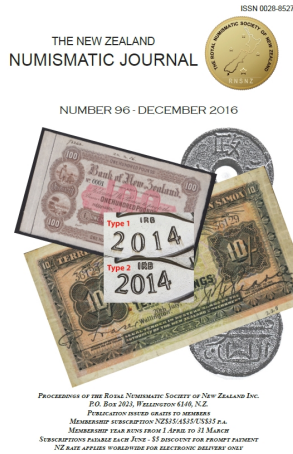

New Zealand
Numismatic Journal

© RNSNZ 1947-
ISSN 0028-8527

Royal Numismatic Society of New Zealand Inc
P O Box 2023, WELLINGTON 6140, NEW ZEALAND
E-mail: Secretary@RNSNZ.org.nz
Website: www.RNSNZ.org.nz or www.RNSNZ.com
Issue 73 Editor: David Galt

NEWSLETTER MAY 2017

COMING SOCIETY MEETINGS

RNSNZ Programme 2017		
Wednesday 26 April	St Andrew's 7.30pm	Wayne Neuman "The Wellington Hoard Find" - Hear why the UK hoard discovery was one of the most significant recent numismatic events
Wednesday 31 May	St Andrew's 7.30pm	Martin Purdy with Rodney Hall - A show-and-tell on "primitive money"
Wednesday 28 June	St Andrew's Meeting Room 2 - upstairs, not our usual room 7.30pm	Members talks. Everyone has something to share that they know about - we look forward to your talk or "show and tell" of up to 5 minutes.
Friday 14 - Monday 17 July	Quality Hotel, Parnell, Auckland	Decimal 50 Conference. Celebrate the 50 th anniversary of decimal currency in Auckland with the NSA and RNSNZ's joint conference. See inside for details or find the brochure and registration form at www.RNSNZ.org.nz .
Wednesday 26 July	St Andrew's 7.30pm	Don't delay - register now. AGM. This is scheduled after the Auckland Conference this year, to allow time for preparation of accounts
Wednesday 30 August	St Andrew's 7.30pm	RNSNZ annual auction, Cliff Leiby and Flemming Scorsen.
Wednesday 27 September	St Andrew's 7.30pm	Coins and banknote records will be brought from the Archives for viewing. See their updated website at www.coincollecting.co.nz

Newsletter of the Royal
Numismatic Society of
NZ Inc.

© RNSNZ 1984-
(current series)

NUMISMATIC SOCIETY OF AUCKLAND INC
P O Box 818, Auckland 1140, New Zealand

MINTMARK
No 440 (OCT. 2011)
Patron: ROBERT LOOSLEY



The Society's 42nd Annual General Meeting and Election of Officers will take place on Wednesday 13 October. Covid prevention, as advised (as we did last year), commencing at 7.30pm. There is a maximum of five persons under the current restrictions, so those who wish to attend are asked to email the President in advance and receive directions. Once we have the confirmed attendees, we will ask for anyone else who would exceed the maximum, to make a prior arrangement with someone who will be present. They can then be telephoned from the meeting to participate in voting or raise a number during proceedings. The speaker will be Peter Duncan on The Birthdays of Charles I. Please bring a mail - My address is ndrew@andrewcliffed.com

OFFICERS OF THE SOCIETY
President: Andrew Clifford
Vice President: D M Bauld
Secretary: J B Duncan
Treasurer & Spokes: Andrew P Duncan
Executive Committee: G Campbell, J Lee, J Dimes, P Ecker, T Gossard, D O'Brien
Editor: J B Duncan, Webmaster: H Gossard

The Society issues on the second Wednesday of each month (except January), and publishes the Society's magazine MINTMARK 11 issues a year.

Subscription rates are \$20 per annum from Sep. 1.

The journal, prepared in 3-DTP/LA2E, is set on a variety of faces of the Society. To contact The Editor - jim@andrewcliffed.com Society AIB: A/c no. 12-1011-470111-00

Mintmark
Newsletter of the
Numismatic Society of
Auckland Inc.

© NSA 1959-

Latest Additions

2021-Dec-01

General	Layout adjustments
1940/CEN/16D	New mounting
1940/CEN/18A.2	New enamel colour
1940/CEN/18B.5	New enamel colour
1940/CEN/21	New photos
1940/CEN/27A.3	New enamel colour
1940/CEN/38	New photos
1940/EXH/8	Version with suspension bar illustrated

2021-Jun-01

1940/CEN/11C.5	New enamel combination
1940/CEN/19A.2	New enamel combination
1940/CEN/46	New entry (Girls' Life Brigade)
1940/EXH/17	Illustrations added

2021-Feb-01

1940/CEN/25B	New variety
1940/CEN/27B.3	New enamel combination

2020-Dec-01

1940/CEN/4A	New "coat of arms" issue
1940/CEN/14C	New entry
1940/CEN/15A.2	Illustration and description added
1940/CEN/17	This section re-numbered to accommodate new single-ribbon variety
17A.1 -> 17B.1	
17A.2 -> 17B.2	
1940/CEN/18B.4	New variety
1940/CEN/37A.3	New variety
1940/CEN/39G	New subtype
1940/EXH/8	New colour illustrations

Amendments & Updates to 1996/2000 Edition

1996/2000 Edition	This Edition	Detail
1939-40/1	1939-40/EXH/1	
1940/1	1940/CEN/1	
1940/2	1940/CEN/1B	
1940/3	1940/CEN/15	
1940/4	1940/CEN/10	
1940/5	1940/CEN/24	
1940/6	1940/CEN/16	
1940/6A	1940/CEN/16A	
1940/6B	1940/CEN/16B	
1940/6C	1940/CEN/16C	
1940/7	1940/CEN/29	
1940/8	1940/EXH/1	
1940/9	1940/EXH/2	
1940/9A	1940/EXH/2A	
1940/9B	1940/EXH/2B	
1940/9C	1940/EXH/2C	
1940/9D	1940/EXH/2	
1940/9E	1940/EXH/2C	
1940/10	1940/EXH/3	
1940/11	1940/EXH/7	
1940/12	1940/EXH/8	
1940/13	1940/CEN/5	1940/13 per 2 nd ed
1940/13	1940/EXH/4.1	1940/13 accidentally duplicated in Supplement
1940/14	1940/EXH/5	
1940/15	1940/EXH/5A	
1940/16	1940/CEN/29A	
1940/17	1940/CEN/14	
1940/18	1940/CEN/35	
1940/19	1940/CEN/11, 12	
1940/20	1940/CEN/25	
1940/21	1940/CEN/27	
1940/22	1940/CEN/2	
1940/23	1940/EXH/12	
1940/24	1940/EXH/13	
1940/25	1940/CEN/45	

Previous catalogue numbers are given in brackets under the current catalogue number. “(-)” below the current catalogue number indicates a new entry, not logged in the 1996 edition or the 2000 Supplement.

Commemorative Medals – 1939-40 – Centennial Issues

Introduction (Leon Morel, *Supplement*, 2000):

Of all the commemorative issues during the 1865-1940 period those issued for the New Zealand 1940 Centennial Exhibition overall are the poorest examples of medallic workmanship. The abysmal issues for that historical event are only saved from total denigration by the New Zealand Numismatic Society [later RNSNZ] commemorative 1940/1 [now 1940/CEN/1] and the International Photography Medal 1940/11 [now 1940/EXH/7]. Strictly the remainder are cheap souvenirs and I contemplated deleting the majority because of this. My dilemma was resolved when I examined a wider range of 1940 souvenirs and decided instead of deleting any to do the opposite and record all. This decision was made because of the importance of the event. Further there was no record of these pieces. Finally, many were of unusual design and quite interesting. Hence my decision to record all the 1940 pieces even if not strictly within the general criteria used throughout the remainder of the book. Information on any additional pieces would be most welcome.

Note (2020): To accommodate the many new issues and varieties discovered since 2000 and to maintain Leon's original (1996) distinction between Centennial and Exhibition commemoratives, this section has been completely renumbered, and now includes the infixes "CEN" and "EXH" to allow for future additions in each sequence.

NEW ZEALAND NUMISMATIC SOCIETY

1940/CEN/1
(1940/1)

Diameter 38 mm

<u>Metal</u>		<u>Rarity</u>
Gilt	R5	
Silver		R3
Bronze		R2



[1.1]

Obverse Māori canoe with tree fern in foreground. NEW ZEALAND CENTENNIAL around above. In minute letters M & K GW

Reverse Vessel Awatea to L with aeroplane above. 1840 . A CENTURY OF PROGRESS . 1940 around above; N.Z. NUMISMATIC / SOCIETY in exergue

Issue Struck by Mayer & Kean. Designed by J. Berry. Engraved by G. Whitehouse. Obverse designer T.H. Jenkin, Invercargill. Issue price 7/6 silver, 3/6 bronze

Versions 1940/CEN/1/1 Gilt (30.4 g and 25.3 g recorded)
1940/CEN/1.2 Silver (30.3 g)
1940/CEN/1.3 Bronze (31.6 g and 25.5 g recorded)





[1.2]



[1.3]



	<p>1940/CEN/1A (-)</p> <p>Diameter 38 mm</p> <p><u>Metal</u> Bronze (25.2 g)</p>	<p><u>Rarity</u> R7</p> 
Obverse	Like 1940/CEN/1 but extra clouds in obverse field and leaves extend into L of CENTENNIAL.	
Reverse	Like 1940/CEN/1	
Note	<i>Trial issue, reworked into 1940/CEN/1</i>	



1940/CEN/1B
(1940/2)

Diameter 38 mm

Metal
Silver Gilt
Silver
Bronze

Rarity
R6
R6
R6

[1B.1]



Obverse Like 1940/CEN/1

Reverse Like 1940/CEN/1 but engraving between sea-plane and vessel and in exergue panel from which inscription has been erased. In three lines N.Z. CENT & IXTH AUST. / PHILATELIC EXH. / . 1940 .

Note *Three types of award were made at the New Zealand Centennial and IX Australasian Philatelic Exhibition. First prize Gilded silver medal, second the Silver medal, and third the Bronze (Supplement, p. 18)*

Versions CEN/1B.1 Silver gilt
CEN/1B.2 Silver
CEN/1B.3 Bronze





[1B.2]







[Illustration required]



[1B.3]



[Illustration required]

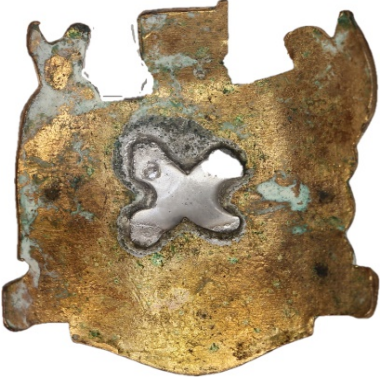

	<p>1940/CEN/1C (-)</p>	
	<p>Diameter 38 mm</p> <p><u>Metal</u> Silver</p>	
<p>As 1940/CEN/1B but reverse exergue panel unengraved.</p>		

	<p>1940/CEN/2 (1940/22)</p>	
	<p>Diameter 27 mm</p> <p><u>Metal</u> Gilt, enamelled</p>	
<p>Obverse</p>	<p>NZ Arms with double ribbon below: NEW ZEALAND / N.Z. CENTENARY 1940. Arms enamelled in correct colours. All inscriptions except ONWARDS on blue enamel</p>	
<p>Reverse</p>	<p>Blank with pin back</p>	

	<p>1940/CEN/3 (-)</p>	
	<p>Diameter 25 mm</p> <p><u>Metal</u> Brass, enamelled</p>	
<p>Obverse</p>	<p>NZ arms; 1840 DUNEDIN N.Z. 1940 on ribbon below</p>	
<p>Reverse</p>	<p>Blank with pin back</p>	

1940/CEN/3A		
(-)		
	Diameter 25 mm	<u>Rarity</u> R?
	<u>Metal</u> Brass, enamelled	
Obverse NZ arms; 1840 HOKITIKA N.Z. 1940 on ribbon below		
Reverse Blank with pin back?		

1940/CEN/4		
(-)		
	Diameter 21.8 x 20.0 mm (excluding mount)	<u>Rarity</u> R5
	<u>Metal</u> Brass, enamelled	
Obverse NZ arms; NEW ZEALAND / CENTENNIAL 1940 on two ribbons below		
Reverse Blank with brooch pin back		

1940/CEN/4A		
(-)		
	Diameter 38.4 x 37.3 mm	<u>Rarity</u> R5
	<u>Metal</u> Tin surround, woven insert	
Obverse NZ arms; 1840 – 1940 above; the whole in a metal shield-shaped surround		
Reverse Blank with brooch pin back		



1940/CEN/5
(1940/13)



Diameter 45 mm

<u>Metal</u>	<u>Rarity</u>
Bronze	R3

Obverse In centre circle arms of Auckland with inscr AUCKLAND / 1940 below. . NEW ZEALAND . around above; . CENTENNIAL GAMES . around below

Reverse Wreath (centre blank for engraving); maker's mark W & H (Walker & Hall) in minute letters below

Note *These games were cancelled because of World War II*



1940/CEN/6
(-)



Diameter 25.2 x 24.7 mm

<u>Metal</u>	<u>Rarity</u>
Silvered, enamelled	R5

Obverse Arms of the city of Auckland with kiwi bearers; AUCKLAND . N.Z. / N.Z. CENTENARY 1940 on two ribbons below

Reverse Blank



1940/CEN/7
(-)

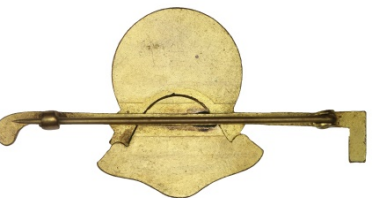



Diameter 28.1 x 24.7 mm
(excluding mount)

<u>Metal</u>	<u>Rarity</u>
...	...

Obverse Arms of Napier; NAPIER . N.Z. / N.Z. CENTENARY 1940 on two ribbons below

Reverse Blank with pin back on riding crop-shaped brooch mount

	<p>1940/CEN/8 (-)</p> <p>Diameter 26 mm</p> <p><u>Metal</u> Brass</p> <p><u>Rarity</u> R?</p>	
Obverse	Shield in centre inscr RAGLAN / PIONEERS. CENTENARY OF N.Z. around above; 1840 – 1940 around below	
Reverse	Blank with pin back	

1940/CEN/9

(-)



Diameter 29.6 mm

Metal
Bronze

Rarity
R?



Obverse In centre circle outline of New Zealand with N to left and Z to right, stylised waves in field. 1840 – CENTENARY – 1940 around above; . NEW ZEALAND . around below

Reverse Blank



1940/CEN/10
(1940/4)

Diameter 26 mm

Metal
Silvered
Copper

Rarity
R6
R6

[Image unavailable]

[10.1]

Obverse Māori chief, head and shoulders $\frac{3}{4}$ facing R in circle. N. Z. CENTENNIAL around above and . 1840-1940 . around below

Reverse Blank with loop suspension, pin back, lapel back and plain back. All plain back examples seem to have had the loop suspension broken off

Versions

- 10.1 Loop suspension
- 10.2 Pin back
- 10.3 Lapel back





[10.2]



[10.3]



1940/CEN/11 (1940/19)	
	Diameter 35.0 x 23.8 mm
<u>Metal</u> Silvered, enamelled	<u>Rarity</u> R5
[11B.1]	
	
Obverse	Medal in shape of Māori chief's head and shoulders with cloak. Ribbon below reading MAORI CHIEF; second ribbon reading CENTENARY (type B) or N.Z. CENTENARY (type C)
Reverse	Blank with pin back (maker's stamp STRATTON/BIRMINGHAM)
Note	<i>Also seen with OTAGO 1848-1948 on ribbon; see 1948 issues in separate chapter</i>
Versions	
11A	Just MAORI CHIEF (1 ribbon) (31.3 x 22 mm)
11A.1	Red enamel
11A.2	Black enamel
11A.3	Pale green enamel
11B	MAORI CHIEF and CENTENARY (2 ribbons) (35 x 23.8 mm)
11B.1	Pale green/Black
11B.2	Red/Black
11B.3	Red/Mid blue
11C	MAORI CHIEF and N.Z. CENTENARY (2 ribbons)
11C.1	Mid-blue/red
11C.2	Pale green/Black
11C.3	Red/Black
11C.4	Red/Mid blue
11C.5	Blue/Blue (note silvered vs. gilt currently uncertain; will be 12C.5 if confirmed gilt)



[11A.1]



[11A.2]



[11A.3]



[11B.1]



[11B.2]



[11B.3]



[11C.1]



[11C.2]



[11C.3]



[11C.4]



[11C.5]

1940/CEN/12

(-)

Diameter 35.0 x 23.8 mm

Metal

Gilt, enamelled

Rarity

R5



[12B.3]



Obverse Medal in shape of Māori chief's head and shoulders with cloak. Ribbon below reading MAORI CHIEF; second ribbon reading CENTENARY.

Reverse Blank with pin back (maker's stamp STRATTON/BIRMINGHAM)

Versions

12B.3 Red/Mid-blue

Note *Example here numbered 12B.3 to match the sequence of types for 1940/CEN/11 in case others are discovered subsequently.*

	<p>1940/CEN/13 (-)</p> <p>Diameter 26.0 x 24.7 mm</p> <table><tr><td><u>Metal</u></td><td><u>Rarity</u></td></tr><tr><td>Silvered, enamelled</td><td>R5</td></tr></table>	<u>Metal</u>	<u>Rarity</u>	Silvered, enamelled	R5	
<u>Metal</u>	<u>Rarity</u>					
Silvered, enamelled	R5					
Obverse	Māori warrior in crouching pose to L (similar to NZ shilling reverse); MAORI WARRIOR / N.Z. on straight ribbon below. N.Z. CENTENARY 1940 on curved ribbon at base					
Reverse	Blank					

1940/CEN/14

(1940/17)

Diameter 22.0 x 31.8 mm

Metal
Gilt, enamelled

Rarity
R5



[14.2]

Obverse Green Tiki with red enamel eyes; TIKI. N. Z. or TIKI. N.Z. / CENTENARY on dark blue enamel on one or two ribbons below

Reverse Blank with pin back

Note For 3-ribbon type with TIKI. N.Z. / NEW ZEALAND / CENTENNIAL EXHIBITION see 1940/EXH/15

Note Also seen with OTAGO 1848-1948 on ribbon; see 1948 issues in separate chapter

Versions

14.1 Just TIKI. N.Z. (1 ribbon) (18.0 x 28.3 mm)

14.1A As 14.1 but mounted on tie clip (black enamel on ribbon; eyes and mouth in red enamel)

14.2 TIKI. N.Z. and CENTENARY (2 ribbons) (22.0 x 31.8 mm)





[14.1]







[14.1A]



[14.2]

	<p>1940/CEN/14A (-)</p> <p>Diameter Unknown</p> <p><u>Metal</u> Gilt, enamelled</p> <p><u>Rarity</u> R6</p>	
<p>Obverse Like 1940/CEN/14 but different style Tiki. Two ribbons, bottom in different shape, reading TIKI. N.Z. / N.Z. CENTENARY 1940</p> <p>Reverse Blank</p>		

	<p>1940/CEN/14B (-)</p> <p>Diameter 24.2 x 24.7 mm (excluding mount)</p> <p><u>Metal</u> Silvered, enamelled</p> <p><u>Rarity</u> R5</p>	
<p>Obverse Tiki with TIKI N.Z. / N.Z. CENTENARY 1940 on two ribbons below</p> <p>Reverse Blank with brooch pin mount</p>		

	<p>1940/CEN/14C (-)</p> <p>Diameter 27 x 31.2 mm</p> <p><u>Metal</u> Gilt, enamelled</p> <p><u>Rarity</u> R5</p>	
<p>Obverse Tiki similar to 1940/CEN/14B with TIKI N.Z. / N.Z. CENTENARY 1940 on two ribbons below, the whole mounted in a circular brooch</p> <p>Reverse Blank with brooch pin mount</p>		

1940/CEN/15

(1940/3)



Diameter 26.8 x 17.1 mm

Metal

Silver

Aluminium

Rarity

R6

R6



[15.2]

Obverse Kiwi to R above crossed ferns; stylised Southern Cross above. 1840 N.Z. CENTENNIAL 1940 in ribbon around below

Reverse Blank (bracteate) with pin back (or loop suspension). Silver version stamped STG SILVER on rev.

Versions

15.1 Silver (pin-back)

15.2 Aluminium (pin-back)

15.2A Aluminium (suspension loop, no pin)



[15.2A]





1940/CEN/16

(1940/6)

Diameter 20.5 x 23.5 mm

Metal
Copper

Rarity
R5

With green, blue & red enamel



[16.1]

Obverse Kiwi to R between fern leaves; Southern Cross above; 1840 1940 on ribbon below. On separate ribbon N.Z. CENTENNIAL

Reverse Blank with pin back or lapel back

Versions

- 16.1 Pin back
- 16.2 Lapel back

[Image unavailable]

[16.2]





1940/CEN/16A
(1940/6A)



Diameter 20.5 x 23.5 mm
(excluding mount)

<u>Metal</u>	<u>Rarity</u>
Copper	R5

With green, blue & red enamel

Obverse Like 1940/CEN/16

Reverse Like 1940/CEN/16 but mounted on lapel pin



1940/CEN/16B
(1940/6B)



Diameter 20.5 x 23.5 mm

<u>Metal</u>	<u>Rarity</u>
Copper	R5

With green, blue & red enamel

Obverse Like 1940/CEN/16

Reverse Like 1940/CEN/16 but mounted on coat pin



1940/CEN/16C
(1940/6C)





Diameter 20.5 x 23.5 mm

<u>Metal</u>	<u>Rarity</u>
Copper	R5

With green, blue & red enamel

Obverse Like 1940/CEN/16

Reverse Like 1940/CEN/16 but mounted on wishbone-shaped pin

	<p>1940/CEN/16D (-)</p> <p>Diameter (TBC)</p> <p><u>Metal</u> Copper</p>	<p><u>Rarity</u> R5</p>	
Obverse	Like 1940/CEN/16		
Reverse	Like 1940/CEN/16 but mounted on an anchor		

1940/CEN/17

(-)

Diameter 35.3 x 31.9 mm

Metal

Gilt, enamelled

Silvered, enamelled

Rarity

R5

R5



[17B.2]

Obverse Medal in shape of kiwi to L with chick to R. Two ribbons below inscr NEW ZEALAND / CENTENARY

Reverse Blank with pin back

Versions

17A Gilt kiwi, single ribbon, 31.3 x 27.3 mm

17A.1 Blue enamel

17B Gilt kiwi, two ribbons

17B.1 Red and mid-blue enamel

17B.2 Light green and dark blue enamel

17C *Silvered kiwi, single ribbon (reserved)*

17D *Silvered kiwi, two ribbons (reserved)*



[17A.1]



[17B.1]



[17B.2]

1940/CEN/18

(-)



Diameter 34.7 x 32.3 mm

Metal
Gilt, enamelled

Rarity
R5



[18B.1]

Obverse Medal in shape of kiwi to L. Two ribbons below inscr NEW ZEALAND / CENTENARY

Reverse Blank with pin back

Note *Also seen with OTAGO 1848-1948 on ribbon; see 1948 issues in separate chapter*

Versions

- 18A Straight beak, single ribbon
- 18A.1 NEW ZEALAND on black enamel; STRATTON'S / MADE IN ENGLAND on rev.
- 18A.2 Red enamel

- 18B Straight beak, two ribbons
- 18B.1 Red and black enamel
- 18B.2 Pale green and black enamel
- 18B.3 Mid-blue and black enamel
- 18B.4 Red and red enamel (no pin back, seen on lid of commemorative powder compact)
- 18B.5 Red and pale blue enamel, pin back

- 18C *(Reserved for curved beak, single ribbon type)*
- 18C.1 *(Reserved)*

- 18D Curved beak
- 18D.1 Dark blue and red enamel
- 18D.2 Red and mid-blue enamel

[Reserved for 18A.1]



[18A.2]



[18B.1]



[18B.2]



[18B.3]



[18B.4 obv]



[18B.4 rev]



[18B.5]

[Reserved for 18C.1]



[18D.1]



[18D.2]

1940/CEN/19

(-)



Diameter 34.7 x 32.3 mm

Metal

Silvered, enamelled

Rarity

R5

[Image unavailable]

[19A.1]

Obverse Like 1940/CEN/18 but silvered. Medal in shape of kiwi to L. One or two ribbons below, inscr NEW ZEALAND or NEW ZEALAND / CENTENARY

Reverse Blank with pin back

Versions

19A Straight beak, single ribbon

19A.1 Black enamel

19A.1A As 19A.1 but mounted on tie clip. STRATTON'S/...ENGLAND on reverse of kiwi; Stratton's/IMITATION/MADE IN ENGLAND on clip

19A.2 Red enamel

19B Straight beak, two ribbons

19B.1 Pale green and black enamel

19B.2 Red and blue enamel

19B.3 Red and black enamel

19C *(Reserved for curved beak, single ribbon type)*

19C.1 *(Reserved)*

19D Curved beak, two ribbons

19D.1 Pale green and black enamel

19D.2 Red and mid-blue enamel



[19A.1]



[19A.1A]



[19B.1]

[Reserved for 19B.2]



[19B.3]

[Reserved for 19C.1]



[19D.1]



[19D.2]

1940/CEN/20

(-)

Diameter 15.4 mm
(excluding mount)



Metal Rarity
Silvered, enamelled R5

Obverse Kiwi to L in centre circle. NEW ZEALAND CENTENARY around above; * 1840 – 1940 *
 around below

Reverse Blank with tie pin back

1940/CEN/21
(-)



Diameter 25.7 x 26.4 mm

<u>Metal</u>	<u>Rarity</u>
Silvered, enamelled	R5

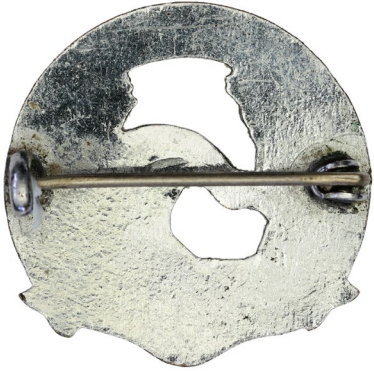

Obverse Kiwi to L between fern leaves in centre circle. Field behind kiwi cut out. NEW ZEALANDS' [sic] CENTENNIAL around above; * 1940 * around below

Reverse Blank with pin clip

1940/CEN/21A
(-)



Diameter 25.7 x 26.4 mm
(excluding mount)

<u>Metal</u>	<u>Rarity</u>
Silvered, enamelled	R5



Obverse Similar to CEN/21

Reverse Similar to CEN/21 but mounted on clip

1940/CEN/22

(-)



Diameter 26.6 x 24.7 mm
(excluding mount)

Metal
Silvered, enamelled

Rarity
R5

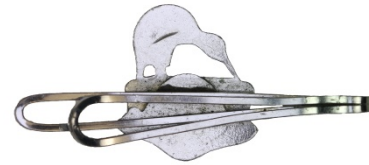

Obverse Kiwi to L. NEW ZEALAND KIWI on straight ribbon below. N.Z. CENTENARY 1940 on curved ribbon at base

Reverse Blank with clip back

1940/CEN/23

(-)

Diameter 34 x 22 mm

Metal
Gilt, enamelled

Rarity
R5



[23.1]

Obverse Multi-coloured kiwi to R against wishbone-shaped brooch. N.Z. CENTENARY against blue enamel on ribbon curving up to L

Reverse Blank with pin back on wishbone-shaped brooch

Note For a version with two ribbons and CENTENNIAL EXHIBITION see 1940/EXH/17

Versions

23.1 Red enamel back with "N.Z. CENTENARY" on ribbon

23.2 Green enamel back with "CENTENARY" on ribbon



[23.1]



[23.2]

	<p>1940/CEN/24 (1940/5)</p>					
	<p>Diameter 26.5 mm</p> <table border="0"> <tr> <td><u>Metal</u></td> <td><u>Rarity</u></td> </tr> <tr> <td>Silvered</td> <td>R5</td> </tr> <tr> <td>Copper</td> <td>R5</td> </tr> </table>		<u>Metal</u>	<u>Rarity</u>	Silvered	R5
<u>Metal</u>	<u>Rarity</u>					
Silvered	R5					
Copper	R5					
[24.1]						
Obverse	Exhibition buildings and flags. NEW ZEALAND CENTENNIAL around above; 1840 . 1940 around below					
Reverse	Blank with lapel back or pin back; also blank (pierced)					
Note	<i>Copper version with plain back noted</i>					
Versions						
24.1	Lapel back					
24.2	Pin back					
24.3	Pierced					
24.4	Plain back (copper)					
	[24.1]					
	[24.3]					

[Image unavailable]

[24.4]

[Image unavailable]



1940/CEN/25
(1940/20)

Diameter 37 x 20 mm

Metal
Gilt, enamelled

Rarity
R6



Obverse Carved Māori gate at Whakarewarewa. CENTENARY on curved ribbon across centre; MAORI PA WHAKA on ribbon below

Reverse Blank with pin back (maker's mark STRATTON / BIRMINGHAM)



1940/CEN/25A
(-)

Diameter 37 x 20 mm

Metal
Bronze, enamelled

Rarity
R6



Obverse Carved Māori gate at Whakarewarewa. N.Z. CENTENARY on curved ribbon across centre; MAORI PA WHAKA on ribbon below. Note central scroll curves up much more sharply than CEN/26

Reverse Blank with pin back (maker's mark STRATTON & Co / BIRMINGHAM)



1940/CEN/25B
(-)

Diameter 37 x 20 mm

Metal
Bronze, enamelled

Rarity
R6

As CEN/25 and 25A but no "CENTENARY" ribbon. MAORI PA WHAKA against green enamel



1940/CEN/26

(-)

Diameter 37 x 20 mm

Metal
Bronze, enamelled

Rarity
R6

[26A.1]



Obverse Like 1940/CEN/26 but kiwi to R emerging from archway and no central ribbon

Reverse Blank with pin-back (maker's mark STRATTON / or STRATTON & Co /)

Versions

26A. Single ribbon at base (MAORI PA WHAKA)

26A.1 Dark blue enamel

26A.2 Red enamel

26A.3 Pale green enamel

26B. Two ribbons at base (MAORI PA WHAKA on straight ribbon and N.Z. CENTENARY on curved ribbon below) (43.7 x 22.5 mm)

26B.1 Pale green and black enamel

26B.2 Red and mid-blue enamel

26B.3 Red and black enamel



[26A.1]



[26A.2]



[26A.3]



[26B.1]



[26B.2]



[26B.3]

1940/CEN/27

(1940/21)



Diameter 33.7 x 28.8 mm

Metal

Silvered, enamelled

Bronze, enamelled

Rarity

R5

R5



[27B.1]

Obverse Medal in shape of Māori whare. Inscr MAORI WHARE below. In straight ribbon below NEW ZEALAND on enamelled background, and CENTENARY in curved enamelled ribbon attached at two points below

Reverse Blank with pin back (maker's mark STRATTON / BIRMINGHAM / ENGLAND)

Note: Also seen with OTAGO 1848-1948 on ribbon; see 1948 issues in separate chapter

Versions

27A Silvered, single ribbon (NEW ZEALAND) (28.8 x 26.8 mm)

27A.1 Red enamel

27A.2 Blue enamel

27A.3 Green enamel

27B Two ribbons (NEW ZEALAND / CENTENARY) (33.7 x 28.8 mm)

27B.1 Red and black enamel

27B.2 Red and blue enamel

27B.3 Green and blue enamel

27C Two ribbons (NEW ZEALAND / N.Z. CENTENARY) (33.7 x 28.8 mm)

27C.1 Red and black enamel

27D (Reserved for bronze finish, types as 27A)

27D.1 (Reserved)

27E As 27B but bronze finish

27E.1 Pale green on both ribbons

27F (Reserved for bronze finish, types as 27C)

27F.1 (Reserved)



[27A.1]



[27A.2]



[27A.3]



[27B.1]



[27B.2]



[27B.3]



[27C.1]



[27E.1]

1940/CEN/28

(-)

Diameter 32.7 x 24.7 mm

Metal
Silvered, enamelled

Rarity
R5



Obverse Like 1940/CEN/27 but different shaped whare. Inscr MAORI WHARE below. Two ribbons blow with inscr NEW ZEALAND / N.Z. CENTENARY 1940

Reverse Blank with pin back in shape of riding crop

1940/CEN/29

(1940/7)

Diameter 25 mm

[Image unavailable]

Metal

Rarity

[Image unavailable]

Silvered

R6

With blue, green & red enamel

Obverse Tree fern in centre circle; to left of tree, sailing ship and Māori whare below; to right of tree steam ship with skyscrapers, cranes, etc., below. In outer circle NEW ZEALAND CENTENNIAL around above; decorative Māori patterns below

Reverse Blank with clip back

1940/CEN/29A

(1940/16)



Diameter medallion 22 mm
extension 26 mm

<u>Metal</u>	<u>Rarity</u>
Brass/gilt	R5
Silvered	R5
With/without enamel	
[29A.2]	



Obverse Like 1940/CEN/29 but base extended in form of open book white enamel pages on which 1840 and 1940

Reverse Blank with plain or pin back

Versions

- 29A.1 None (some with flan flaws)
- 29A.2 Pale blue/dark blue/green
- 29A.3 Pale blue/dark blue with red surround
- 29A.4 Pale blue/ green/red/red surround
- 29A.5 Pale blue/green/red/red surround
- 29A.6 Pale blue/ green/red surround



[29A.1]



[29A.2]



[29A.3]





[29A.4]





[29A.5]



[29A.6]

1940/CEN/30 (-)		
	Diameter 18-19 mm (excluding mount)	
	<u>Metal</u>	<u>Rarity</u>
	Silver	R5
	Silvered	R5
Obverse	Vertical line divides "1840" and "1940" scenes; N.Z./CENTENARY in ex.	
Reverse	Blank with pin (maker's stamp YOUNG & CO LD / AUCK)	

		1940/CEN/31
		(-)
	Diameter	49 x 30 mm
	<u>Metal</u>	<u>Rarity</u>
	Enamelled	R?
Obverse	Karapiti blowhole; THE FAMOUS KARAPITI BLOWHOLE on ribbon around above; WONDERFUL WAIRAKEI NZ / N.Z. CENTENARY 1940 on ribbons below	
Reverse	Blank with pin (tie-pin?) back	

	1940/CEN/32 (-)	
	Diameter 30 x 23 mm Loop suspension	[Image unavailable]
	<u>Metal</u> Enamelled	<u>Rarity</u> R5
Obverse	Outline of Stewart Island; on ribbon around above; STEWART ISLAND NZ / N.Z. CENTENARY 1940 on ribbons blow	
Reverse	Blank	

1940/CEN/33

(-)



Diameter 29.4 x 24.7 mm

Metal
Enamelled

Rarity
R5

[Image unavailable]

Obverse Drop Scene on Whanganui River; THE FAMOUS DROP SCENE around above; WANGANUI RIVER N.Z. / N.Z. CENTENARY 1940 in two ribbons below

Reverse Blank with pin back (pin mounted to circle frame)

1940/CEN/34

(-)



Diameter 28.2 x 16 mm

Metal
Enamelled

Rarity
R?



[34.1]

Obverse 1840 – 1940 superimposed on fern leaf shape; N Z CENTENARY on ribbon below

Reverse Blank with pin back

Versions

34.1 Black

34.2 Pale blue (8 of 1840 cut over a 6?)

34.3 Pale green (8 of 1840 cut over a 6?)



[34.1]



[34.2]



[34.3]

1940/CEN/35

(1940/18)

Diameter 38.5 mm

Metal
Copper, enamelled

Rarity
R5



[35.1]

Obverse N.Z. CENTENARY on dark blue enamel ribbon, superimposed on spokes of ship's wheel. Light blue enamel on outer band; version with cream-coloured enamel also noted

Reverse Blank with pin back

Versions

35.1 Light blue enamel



35.2 Cream enamel









[35.1]





[35.2]

	<p>1940/CEN/36 (-)</p> <p>Diameter 33.5 x 18.8 mm</p> <p><u>Metal</u> Brass, enamelled</p> <p><u>Rarity</u> R5</p>	
Obverse	Brooch in wishbone shape; CENTENARY in curved ribbon across centre	
Reverse	Blank with pin back	

1940/CEN/37		
(-)		
	<p>Diameter 25 x 23 mm</p> <p><u>Metal</u> Brass, enamelled</p>	<p><u>Rarity</u> R5</p>
		
Obverse	Brooch in horseshoe shape; N.Z. CENTENARY in curved ribbon below. Green enamel on horseshoe, blue on ribbon	
Reverse	Blank with pin back	

1940/CEN/37A		
(-)		
	<p>Diameter 25 x 26 mm</p> <p><u>Metal</u> Brass, enamelled</p>	<p><u>Rarity</u> R5</p>
		
	[37A.3]	
Obverse	Like 1940/CEN/37. Brooch in horseshoe shape with kiwi in centre to R; CENTENARY in curved ribbon below.	
Reverse	Blank with pin back	
Versions		
37A.1	Multicoloured kiwi; blue enamel on horseshoe and ribbon	
37A.2	Multicoloured kiwi; red enamel on horseshoe and blue on ribbon	
37A.3	Multicoloured kiwi; green enamel on horseshoe and blue on ribbon	
		
[37A.1]	[37A.2]	

	<p>1940/CEN/37G (-)</p> <p>Diameter 22.5 x 24.1 mm</p> <p><u>Metal</u> Brass, enamelled</p> <p><u>Rarity</u> R5</p>	
Obverse	Similar to 1940/CEN/37 but brooch in full circle shape. Kiwi in white enamel. Legend N.Z. CENTENARY on black enamel in curved ribbon below.	
Reverse	Blank with pin back	

1940/CEN/38

(-)

Diameter 37.7 x 33.7 mm

Metal

Brass, enamelled

Rarity

R5



Obverse Medal in shape of seagull in flight; N.Z. CENTENARY in ribbon below (blue enamel)

Reverse Blank with pin back; maker's mark STRATTON / BIRMINGHAM / COPYRIGHT

1940/CEN/39

(-)

Diameter 50.5 x 16 mm





Metal
Brass, enamelled

Rarity
R5



Obverse Medal in shape of flying boat to L; CENTENARY in ribbon by fuselage (blue enamel); G-55 on side of plane near tail

Reverse Blank with pin back; maker's mark STRATTON / BIRMINGHAM

	<p>1940/CEN/40 (-)</p> <p>Diameter 45.5 x 42.4 mm</p> <p><u>Metal</u> Brass, enamelled</p> <p><u>Rarity</u> R5</p>	
Obverse	Badge in shape of yacht to R; CENTENARY in ribbon on side of hull (multicoloured enamel: pennants red, sails white, ribbon and hull dark blue, sea green)	
Reverse	Blank with pin back; maker's mark STRATTON / BIRMINGHAM / COPYRIGHT	

1940/CEN/41

(-)



Diameter 41.6 x 19.6 mm

Pin back

Metal

Brass, enamelled



Rarity



R5







Obverse Badge in shape of two-masted liner to L with oversized kiwi to R toward bow; N.Z. CENTENARY in ribbon on side of hull (multicoloured enamel: white kiwi, upper decks white, top of smokestacks, ribbon and hull dark blue)

Reverse Blank with pin back; maker's marks MADE IN / ENGLAND and STRATTON & Co / BIRMINGHAM



1940/CEN/42 (-)	
Diameter 62 x 22.4 mm	
<u>Metal</u> <u>Rarity</u> Brass, enamelled R5	
	
Obverse	Badge in shape of a golf bag with heads of four clubs visible; white kiwi superimposed with curved blue ribbon reading N.Z. CENTENARY below
Reverse	Blank with pin back; maker's marks STRATTON / BIRMINGHAM / COPYRIGHT

		<p>1940/CEN/43 (S. 558)</p>		
		<p>Diameter 41 mm</p> <p><u>Metal</u> Bronze</p>	<p><u>Rarity</u> R5</p>	
Obverse	<p>Hand clasping thunderbolts rising from stylised waves; sun above with rays in background, the whole within a chain circle. THE NEW ZEALAND INSTITUTION OF ENGINEERS around above; * INCORPORATED 1914 * around below</p>			
Reverse	<p>Māori whare with inscr PRESENTED / TO below roofline, 1940 below building. NEW ZEALAND CENTENNIAL around above; WELLINGTON N.Z. around below. Decorative Māori motifs around rim.</p>			
Issue	<p>Struck by Mayer & Kean; 16 examples awarded to contributors of papers (Sutherland)</p>			



1940/CEN/44		
(-)		
Diameter 27 x 18 mm		
<u>Metal</u>		<u>Rarity</u>
Silvered, red enamel		R5
		
Obverse	Medal in shape of monstrance with red enamel sections. 1840 N.Z. 1940 / NAT. EUCH. CONG. in curved box below	
Reverse	Plain with pin back (with maker's stamp)	
Issue	For the National Eucharistic Congress, Wellington, from 4 February 1940	
Note	<i>Two varieties of maker's stamp noted: "THEO MEYER/AUCK." in centre of rosette, and "NO. 4308/THEO MEYER/AUCK." occupying lower half of rosette.</i>	



1940/CEN/45		
(1940/25)		
	Diameter 32.4 mm	
	<u>Metal</u> Printed design Cellulose cover	<u>Rarity</u> R5
	Obverse	Carillon in part-circle of Māori motifs with kiwi to L below. N.Z CENTENARY 1940 in white letters around above
Reverse	Plain with pin back	
Issue	Manufactured by W. Seaton & Co., Wellington (W. SEATON & CO 15 CUBA ST WGTN on edge)	



1940/CEN/45A		
(-)		
	Diameter 28.2 mm	
	<u>Metal</u> Printed design Cellulose cover	<u>Rarity</u> R5
	Obverse	In centre circle tree fern with “then” and “now” motifs to left and right. NEW ZEALAND CENTENNIAL around above; 1840 . 1940 around below, with decorative Māori motifs as text dividers
Reverse	Plain with pin back	

	1940/CEN/45A.1		
	(-)		
	Diameter	32 mm	
	<u>Metal</u>		<u>Rarity</u>
	Printed design		R5
	Cellulose cover		
Obverse	Like 1940/CEN/45A but with smaller letters and slightly different detail in centre section		
Reverse	Plain with pin back		

	1940/CEN/45B		
	(-)		
	Diameter	28.2 mm	
	<u>Metal</u>		<u>Rarity</u>
	Printed design		R5
	Cellulose cover		
Obverse	Koruru in centre; NEW ZEALAND in curved frame above; CENTENNIAL 1940 in curved frame below		
Reverse	Plain with pin back		

	1940/CEN/45C		
	(-)		
	Diameter	28.2 mm	
	<u>Metal</u>		<u>Rarity</u>
	Printed design		R5
	Cellulose cover		
Obverse	Kiwi to R in centre. NEW ZEALAND in curved ribbon above; CENTENNIAL 1940 in curved ribbon below		
Reverse	Plain with pin back		

	<p>1940/CEN/45D (-)</p> <p>Diameter 28.2 mm</p> <p><u>Metal</u> Printed design Cellulose cover</p> <p><u>Rarity</u> R5</p>	
Obverse	Carillon in centre; NEW ZEALAND around above; CENTENNIAL 1940 around below	
Reverse	Plain with pin back	

	<p>1940/CEN/45E (-)</p> <p>Diameter 28.2 mm</p> <p><u>Metal</u> Printed design Cellulose cover</p> <p><u>Rarity</u> R5</p>	
Obverse	In centre, sailing vessel and aeroplane over cloud pattern. NEW ZEALAND CENTENNIAL around above; 1840 . 1940 around below	
Reverse	Plain with pin back	

1940/CEN/45F		
(-)		
	Diameter 28.2 mm	
	<u>Metal</u>	<u>Rarity</u>
	Printed design	R5
	Cellulose cover	
Obverse	Head and shoulders of tattooed Māori ¾ facing R with tree behind L and whare behind R. NEW ZEALAND around above and CENTENNIAL 1940 around below. Koruru as text dividers to L and R	
Reverse	Plain with pin back	

1940/CEN/45G		
(-)		
	Diameter 32.2 mm	
	<u>Metal</u>	<u>Rarity</u>
	Printed design	R5
	Cellulose cover	
Obverse	In centre circle outline map of NZ with NEW ZEALAND CENTENARY around above; in outer circle 1840-1940 around below with Māori kowhaiwhai pattern in black and red at each side and a small kiwi to L at top	
Reverse	Plain with pin back	
Edge	Maker's name H ODELL CHCH	



1940/CEN/45H
(-)



Diameter 32.5 mm

<u>Metal</u>	<u>Rarity</u>
Printed design	R5
Cellulose cover	

Obverse British troops arriving onshore holding Union Jack and meeting a group of local Māori. Bust of Cook in circle above. NEW ZEALAND'S 100TH ANNIVERSARY around above; 1840 – 1940 around below

Reverse Plain with pin back



1940/CEN/46
(-)



Diameter 22 x 29 mm

<u>Metal</u>	<u>Rarity</u>
Brass (?) and enamel	R6

Obverse Girls' Life Brigade initials forming cross in centre; inscr in outer circle around above TO SAVE LIFE. Circle of dots around below. Crown above, N and Z to left and right; 1940 below. In ribbon against red enamel CENTENARY

Reverse Plain with pin back

Commemorative Medals – 1939-40 – Exhibition Issues

	<p>1939-40/EXH/1 (1939-40/1)</p>	
	<p>Diameter 26.75 x 21 mm Loop suspension</p>	
	<p><u>Metal</u> Bronze, blue enamel Chromed</p>	<p><u>Rarity</u> R6 R6</p>
	<p>[1.2]</p>	
<p>Obverse</p>	<p>* CENTENNIAL / * * / EXHIBITION * in centre between fern leaves; NEW ZEALAND around above; 1939-40 around below</p>	
<p>Reverse</p>	<p>In centre circle, outline map of England and Wales with London and Dagenham marked and Ford logo below. In outer circle, A BRITISH PRODUCT. around above right; MADE AT FORD WORKS DAGENHAM around below. In separate curved box above PREFECT</p>	
<p>Versions</p>		
<p>1.1</p>	<p>Bronze, blue enamel</p>	
<p>1.2</p>	<p>Chromed</p>	
<p>[Illustration unavailable]</p>	<p>[1.1]</p>	<p>[Illustration unavailable]</p>



1939-40/EXH/2

(-)

Diameter 25.4 x 21.2 mm

Metal

Silvered, enamelled

Rarity



R5



Obverse NZ arms with coloured enamel; 1939-40 in ribbon above; CENTENNIAL EXHIBN/WELLINGTON in two ribbons below, all with blue enamel

Reverse Blank with pin back

	1940/EXH/1 (1940/8)		
	Diameter 25.4 mm <u>Metal</u> Bronze	<u>Rarity</u> R5	
Obverse	In centre circle, Carillon with rays behind. N.Z. CENTENNIAL EXHIBITION around above and 1840.1940 around below		
Reverse	Blank with lapel back		

	1940/EXH/1A (1940/8)		
	Diameter 25.4 mm <u>Metal</u> Brass	<u>Rarity</u> R5	
Obverse	In centre circle, Carillon with rays behind. N.Z. CENTENNIAL EXHIBITION around above and 1840.1940 around below		
Reverse	Blank with lapel pin back; maker's mark BOCK/WELLINGTON		



1940/EXH/2
(1940/9 & 9D)

Diameter 25.4 mm

Metal
Copper

Rarity
R4



[2.1]

Obverse Centre like medal part of 1940/CEN/16. In outer circle THE N.Z. CENTENNIAL EXHIBITION * around

Reverse Blank

Versions



- 2.1 Plain (no enamel)
- 2.2 Enamelled (blue, green, red)







[2.1]







[2.2]



	<p>1940/EXH/2A (1940/9A)</p>	
	<p>Diameter 25.4 mm</p> <p><u>Metal</u> Copper</p> <p><u>Rarity</u> R4</p> <p>With blue, green & red enamel</p>	
<p>Obverse Like 1940/EXH/2 but with loop and ribbon-shaped suspension bar</p> <p>Reverse Blank</p>		



	<p>1940/EXH/2B (1940/9B)</p>	
	<p>Diameter 25.4 mm</p> <p><u>Metal</u> Copper</p> <p><u>Rarity</u> R4</p> <p>With blue, green & red enamel</p>	
<p>Obverse Like 1940/EXH/2 but with loop suspension with gold-coloured bar</p> <p>Reverse Blank</p>		

	<p>1940/EXH/2C (1940/9C & 9E)</p>	
	<p>Diameter 25.4 mm</p> <p><u>Metal</u> Copper</p> <p><u>Rarity</u> R4</p> <p>With blue, green & red enamel</p>	
<p>Obverse Like 1940/EXH/2</p> <p>Reverse Blank but with pin back</p>		

	<p>1940/EXH/2D (-)</p>		
	<p>Diameter 25.4 mm (26.5 mm reported)</p>	<p><u>Metal</u> Copper</p>	
<p>With blue, green & red enamel</p>			
<p>Obverse Like 1940/EXH/2</p>			
<p>Reverse Blank but with lapel back</p>			

	<p>1940/EXH/2E (-)</p>		
	<p>Diameter 25.4 mm (medal) 62.4 mm (pin)</p>	<p><u>Metal</u> Copper</p>	
<p>With blue, green & red enamel</p>			
<p>Obverse Like 1940/EXH/2</p>			
<p>Reverse Blank but with tie pin bar back</p>			

	<p>1940/EXH/2F (-)</p>		
	<p>Diameter 25.4 mm</p>	<p><u>Metal</u> Copper</p>	
<p>With blue, green & red enamel</p>			
<p>Obverse Like 1940/EXH/2</p>			
<p>Reverse Blank but with lapel pin back</p>			

1940/EXH/2G (-)	
Diameter 40 x 38 mm	
<u>Metal</u> Copper	<u>Rarity</u> R6
	
Obverse	Main element Like 1940/EXH/2 but higher relief and no enamel. DOMINION COURT in ribbon below, the whole on an irregularly shaped flan (medallist's pull/test piece)
Reverse	Blank



1940/EXH/3
(1940/10)

Diameter 20.7 mm

Metal
Silvered, enamelled

Rarity
R5



[3.1]

Obverse Like 1940/EXH/2 but smaller flan, thinner kiwi, thinner fern leaves. Note two blobs (whiskers?) by top of kiwi's beak. Line at base instead of star

Reverse Blank with pin back

Versions

- 3.1 Pale blue background in centre circle; outer circle dark blue (pin back)
- 3.2 Dark blue centre, red outer circle
- 3.3 Green centre, red outer circle



[3.1]



[3.2]



[3.3]

1940/EXH/3A

(-)

Diameter 21 mm

Metal
Copper

Rarity
R6



Obverse Like 1940/EXH/3 but thicker leaves; no enamel

Reverse Blank

1940/EXH/4

(-)



Diameter 26.5 mm
(25.4 mm also reported)

<u>Metal</u>	<u>Rarity</u>
Silvered, enamelled	R5

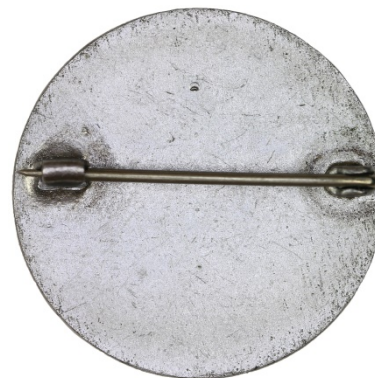

[4.1]

Obverse Like 1940/EXH/2 but thinner kiwi and thinner fern leaves; silver centre and purple outer ring

Reverse Blank with pin back

Versions

4.1 See main description

4.2 As EXH/4.1 but no stop after Z (faint trace under magnification) (previously M1940/13)



[4.2]

1940/EXH/4A
(-)



Diameter 18.6 mm

<u>Metal</u>	<u>Rarity</u>
Gilt, enamelled	R5
Silvered, enamelled	R5



[4A.1]

Obverse Like 1940/EXH/4 but cruder kiwi, ferns and ribbon; dot or star at bottom

Versions

4A.1 Gilt centre with dark blue outer circle (pin back)

4A.2 Gilt centre with dark blue outer circle (lapel back); star at bottom of obv

4A.3 Silvered centre with dark blue outer circle (lapel back)



[4A.1]



[4A.2]



[4A.3]

1940/EXH/4B
(-)





Diameter 19 mm



<u>Metal</u>	<u>Rarity</u>
Copper	R5



Obverse Like 1940/EXH/4 but no enamel and smaller flan; design detail in centre circle incuse





Reverse Blank

	1940/EXH/5 (1940/14)		
	Diameter 15.5 mm <u>Metal</u> Gilt, enamelled	<u>Rarity</u> R5	
[5.1]			
Like 1940/EXH/4 but smaller, no dates on ribbons, no stops in legends; lapel back			
Versions			
5.1	See main description		
5.2	As EXH/5 but brown-coloured kiwi and dot at bottom in outer circle.		
			 [5.2]

	1940/EXH/5A (1940/15)		
	Diameter 15.5 mm (medal); 40.8 x 30.4 mm (anchor)	<u>Metal</u> Gilt, enamelled	
Obverse	Like 1940/EXH/5 but anchor behind medal		
Reverse	Blank with pin back; maker's mark STRATTON & CO BIRMINGHAM		

	<p>1940/EXH/5B (-)</p>	
<p>Diameter 15.5 mm (medal)</p>		
<p><u>Metal</u> Gilt, enamelled</p>		<p><u>Rarity</u> R5</p>
<p>Obverse</p>	<p>Like 1940/EXH/5 but in drop pendant; chain attached to propeller bar</p>	
<p>Reverse</p>	<p>Blank</p>	

	<p>1940/EXH/5C (-)</p>	
<p>Diameter 15.5 mm (medal) 77 mm (tie pin)</p>		
<p><u>Metal</u> Gilt, enamelled</p>		<p><u>Rarity</u> R5</p>
<p>Like 1940/EXH/5 but with stops in legends</p>		
<p>Reverse</p>	<p>Blank with pin back</p>	

	<p>1940/EXH/5D (-)</p> <p>Diameter 15.5 mm (medal) Pin back</p> <p><u>Metal</u> Gilt, enamelled</p> <p><u>Rarity</u> R5</p> <p>[5D.1]</p>	
<p>Like 1940/EXH/5C but on horseshoe</p>		
<p>Reverse Blank with pin back</p>		
<p>Versions</p>		
<p>5D.1 Black horseshoe 5D.2 Blue horseshoe 5D.3 Red horseshoe</p>		
		
[5D.1]	[5D.2]	[5D.3]



1940/EXH/5E

(-)

Diameter 15.5 mm

Metal

Gilt, enamelled

Silvered, enamelled

Rarity

R5

R5

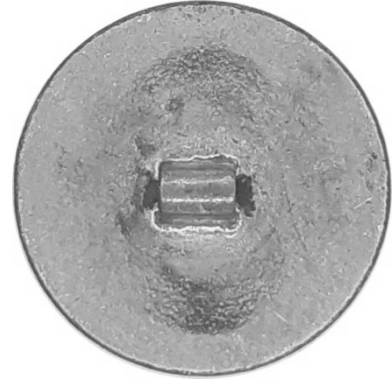

[5E.2]

Obverse Like 1940/EXH/5C but with chain and cuff link

Reverse blank.

Versions

5E.1 Gilt, enamelled

5E.2 Silvered, enamelled

[Illustration unavailable]

[5E.1]

[Illustration unavailable]



1940/EXH/6

(-)

Diameter 20.5 mm

Metal

Gilt, enamelled

Silvered, enamelled

Rarity

R5

R5



[6.2]

Obverse In inner circle, kiwi to R between fern leaves; Southern Cross above and 1940 below; in outer circle CENTENNIAL EXHIBITION around above; . NEW ZEALAND . around below

Reverse Blank (pin back? Attachment broken in examples observed)

Versions

6.1 Gilt centre with red outer circle

6.2 Silvered centre with red outer circle

[Illustration unavailable]

[5E.1]

[Illustration unavailable]



1940/EXH/7
(1940/11)

Diameter 41 mm

Metal
Silver
Bronze

Rarity
R6
R6

[7.2]



Obverse Carillon with rays around above; allegorical female figure with centennial sash and tablet above and behind. INTERNATIONAL SALON OF PHOTOGRAPHY around above. In exergue NEW ZEALAND CENTENNIAL/EXHIBITION

Reverse Wreath; blank in centre for engraving

Issue Struck by Mayer & Kean.

Versions

- 7.1 Silver
- 7.2 Bronze

[Illustration unavailable]



[7.1]

[Illustration unavailable]

	<p>1940/EXH/8 (1940/12)</p>	
	<p>Diameter 33 x 32 mm Loop suspension</p>	
	<p><u>Metal</u> Gilt</p>	<p><u>Rarity</u> R5</p>
<p>Obverse</p>	<p>Kiwi to L in centre; large N to left and Z to right; CENTENNIAL around above and EXHIBITION around below</p>	
<p>Reverse</p>	<p>Blank</p>	
<p>Note</p>	<p><i>There is a strong suggestion that this medal was struck in 1939 and used as an award to Officials' wives. (Supplement, p. 18)</i></p>	
	<p>[With suspension bar]</p>	

Commemorative Medals – 1939-1940 – Exhibition Issues

	<p>1940/EXH/9 (-)</p> <p>Diameter 15.2 mm</p> <p><u>Metal</u> Gilt</p>	<p><u>Rarity</u> R5</p>	
Obverse	White kiwi to L in centre; seven irregular shapes around; KIWI on shape in 6:00 position		
Reverse	Blank with cuff link		
Note	<i>Sold on card reading SOUVENIR / NEW ZEALAND CENTENARY / 1840 – 1940 / MADE IN ENGLAND</i>		

	<p>1940/EXH/10 (-)</p> <p>Diameter 13.6 mm</p> <p><u>Metal</u> Brass</p> <p><u>Rarity</u> R5</p>	
Obverse	Outline of kiwi to L against shaded background. N.Z. CENTENNIAL EXHIBITION around below	
Reverse	Cuff link chain attachment in centre; inscr around MADE IN ENGLAND PAT. 243165 FOREIGN [sic] PATS	

1940/EXH/11

(-)



Diameter 14.5 mm (kiwi)
40 x 20 mm (wishbone)

Metal
Brass

Rarity
R5



Obverse Kiwi to L in wishbone

Reverse Blank with pin back / brooch?

Issue On card reading SOUVENIR OF / NEW ZEALAND CENTENNIAL EXHIBITION / 1840 – 1940

1940/EXH/12

(1940/23)

Diameter 36.0 x 34.5 mm

Metal

Gilt, enamelled

Rarity

R5



[12.1]



Obverse White tower, green and dark blue in foreground with inscription N.Z. CENTENNIAL EXHIBITION / MAIN TOWER on red enamel

Reverse Blank with pin back; maker's mark STRATTON & CO / BIRMINGHAM / ENGLAND

Versions

12.1 As main description

12.2 As 12.1 but with extra green to right of steps above EXHIBITION

12.3 As 12.2 but with extra blue highlights on building



[12.1]



[12.2]



[12.3]

1940/EXH/13
(1940/24)

Diameter 27 x 22 mm

Metal
Gilt, enamelled

Rarity
R5



[13.1]

Obverse Carillon tower gold with legend on dark blue ribbons, light blue behind tower. N.Z. CENTENNIAL EXHIBITION in curved scroll below, date 1940 below scroll

Reverse Blank

Versions

- 13.1 As main description
- 13.2 As 13.1 but tower silver, scroll blue
- 13.3 As 13.1 but tower bronze, scroll blue, pin back



[13.1]



[13.2]



[13.3]

1940/EXH/13A

(-)

Diameter 27 x 22 mm
Brooch bar 45 mm



Metal
Gilt, enamelled

Rarity
R5



Obverse Like 1940/EXH/13

Reverse Like 1940/EXH/13 but on wide brooch back

1940/EXH/13B

(-)

Diameter 27 x 22 mm



Metal
Gilt, enamelled

Rarity
R5



Obverse Like 1940/EXH/13 but loops to L and R of building

Reverse Blank, but remains of pin back mount

1940/EXH/14
(-)



Diameter 32.9 x 22.5 mm

<u>Metal</u>	<u>Rarity</u>
Gilt, enamelled	R5
Silvered, enamelled	R5



[14.1]

Obverse Like 1940/EXH/13 but different shaped ribbon reading CENTENARY EXHIBITION N.Z. More detailed foreground including paths, etc., in coloured enamel. Date in foreground above ribbon

Reverse Blank with Pin back or suspension loop

Versions

14.1 Type as above, plain reverse

14.2 Buildings in gilt finish; suspension loop (also noted with ribbon and suspension bar)



[14.2]



[14.2]

1940/EXH/14A
(-)





Diameter 34 x 26 mm

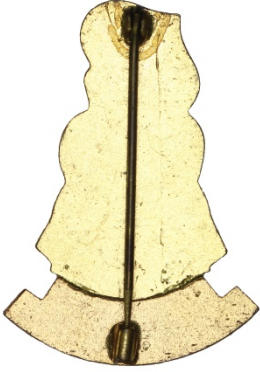

<u>Metal</u>	<u>Rarity</u>	[Image unavailable]
Silvered, enamelled	R5	

Obverse Like 1940/EXH/14

Reverse Blank with 50 mm brooch back

	<p>1940/EXH/15 (-)</p> <p>Diameter 24.0 x 34.6 mm</p> <p><u>Metal</u> Gilt, enamelled</p> <p><u>Rarity</u> R5</p>	
Obverse	Green Tiki with red enamel eyes; TIKI. N. Z. / NEW ZEALAND / CENTENNIAL EXHIBITION on dark blue enamel on three ribbons below	
Reverse	Blank with pin back	
Note	<i>For 1 and 2-ribbon types with TIKI. N.Z. or TIKI. N.Z. / CENTENARY see 1940/CEN/14</i>	

	<p>1940/EXH/16 (-)</p> <p>Diameter 39 x 25 mm</p> <p><u>Metal</u> Brass, enamelled</p> <p><u>Rarity</u> R5</p>	
Obverse	Badge in shape of piper to R; NEW ZEALAND / CENTENNIAL EXHIBITION in two ribbons below (dark blue enamel)	
Reverse	Blank with pin back, maker's mark STRATTON / BIRMINGHAM / COPYRIGHT	

1940/EXH/17 (-)		
	Diameter 34 x 22 mm	
	<u>Metal</u> Gilt, enamelled	<u>Rarity</u> R5
Obverse	Multi-coloured kiwi to R against wishbone-shaped brooch. Two ribbons below reading NEW ZEALAND / CENTENNIAL EXHIBITION against blue enamel on ribbon curving up to L	
Reverse	Blank with pin back on wishbone-shaped brooch	
Note	<i>For versions with a single ribbon see 1940/CEN/23</i>	

List of Makers & Manufacturers

Medallists and Manufacturers

<p>Bock & Sons, Wellington</p>	<p>Established in 1890 by W.R. Bock (1847-1932). General engravers, die sinkers, badge makers, medallists and illuminators. Closed in 1987.</p>
<p>Mayer & Kean (now Mayer & Toye Ltd) 10 College St Te Aro Wellington 6011 +64-4-384-9884 www.mayerandtoye.co.nz</p>	<p>Established in Wellington in 1902. Has traded successively as H.G. Mayer Ltd, Mayer & Kean Ltd., and Mayer & Toye Ltd. In August 2020 the company was acquired by Tribe Design Ltd, and the two brands will eventually merge under the Mayer and Toye Ltd. name.</p>
<p>Theo Meyer 9 Nixon Street Grey Lynn Auckland 1021 +64-9-378-7653 www.badgemakers.co.nz</p>	<p>Established in 1921 and now trading as Badgemakers.</p>
<p>H Odell & Son Christchurch</p>	<p>A printing and stationery firm. In addition to the celluloid badge recorded here it also produced celluloid badges for the proposed coronation of Edward VIII in 1937.</p>
<p>W. Seaton & Co. 15 Cuba Street Te Aro Wellington 6011</p>	
<p>Stratton & Co. Birmingham England</p>	<p>A prolific manufacturer of badges, pins and brooches. Stratton is an offshoot of Jarrett & Rainsford, and Jarrett, Rainsford & Laughton Ltd, with origins dating back to 1860.</p>
<p>Young & Co. Auckland</p>	<p>Manufacturing jewellers, noted in Lorne Street, Auckland, in 1918</p>

List of Makers & Manufacturers

Rarity Scale

To assist the collector in determining the possibility of obtaining any of the listed commemorative pieces, a rarity scale has been included. This is based upon personal collectors and dealers combined knowledge.

No estimates of value have been included as this publication is intended as a numismatic record not a price catalogue. In some respects, it is unnecessary as collectors and dealers already have a market worth and appreciation of commemoratives and will pay accordingly.

As a general rule rarity does not automatically mean that a medallion is highly valuable. In numismatics, prices depend on additional factors to scarcity such as condition and demand. Also, handsome medallions commemorating events or occasions of importance can be worth more than equally or scarcer pieces issued for unimportant or obscure events. For example 1865/1 or 1872/1 both with a R5 rarity are more valuable than 1882/18 with a R6 rarity or 1906-07/39 with an even higher R7.

Also, price quotes quickly become outdated.

R1	very common	
R2	common	
R3	normal scarce	
R4	scarce	
R5	rare	(estimated 11 to 25 known)
R6	very rare	(estimated 4 to 10 known)
R7	extremely rare	(estimated 1 to 3 known)

The rarity figures provided are the compilers' best estimates in each case and are not definitive. The editors would be interested to learn of any known mintage figures or confirmed known quantities that suggest any of the stated estimates should be changed.

About the Authors ...

Martin Purdy FRNSNZ



Martin arrived in New Zealand as a five-year-old in 1970 with a matchbox full of British coins that eventually formed the basis for his collection.

The discovery of coins with legends in foreign languages and different alphabets led him to a career as a translator, though he has remained an active collector and student of coins and medals for over 45 years.

A former President of both the Royal Numismatic Society of New Zealand (2003-2006) and the Wellington Coin Club (1989-1994), and Secretary of the RNSNZ (1990-1997), he was involved in editing and publishing the Society's Journal for over twenty-five years, becoming a Fellow of the Society in 2003.

More recently he collaborated with Hamish MacMaster on larger-scale undertakings such as the two editions of the catalogue of post-1940 Commemorative Medals published in 2009 and 2014, and the first and second editions of the Catalogue of NZ Challenge Coins (2011, 2016). In collaboration with Rodney, he compiled and published a supplement to the 2nd edition in May 2019.

A new initiative is this chapter-by-chapter electronic publication of a third edition of Leon Morel's catalogue of pre-1940 medallic commemoratives, with an electronic third edition of the "MacMaster" post-1940 catalogue being prepared in parallel.

A keen vintage car enthusiast, Martin also edits Sphinx-NZ, the magazine of the Armstrong Siddeley Car Club in NZ.

Jason Gray



Jason started to take an interest in numismatics after being shown a 1993 kingfisher design \$2 coin by his grandfather as a teenager. But it was not until many years later that he started collecting coins himself, joining the Manawatu Numismatic Society in 2007. His interests extended to medals and tokens. However, his passion is in the small details of coin errors, and this is documented on his website coinerrors.nz.

Now Jason works on discovering, photographing, and cataloguing New Zealand coins, tokens, and commemorative medals, and has contributed to the medal and challenge coin catalogues in this series since 2014.

He is a keen kayak angler and loves going on adventures with the family.

Rodney Hall



Rodney was born in an England still gripped by food rationing. At 18 months, he travelled by plane (BOAC Argonaut) via the Middle East and Ceylon to Singapore (a three-day trip with flying only during daylight hours).

He spent the next 13 years overseas in Malaya, Singapore and finally on the island of Zanzibar in East Africa, and has fond memories of sea, sand, and sun on the beaches there, with boarding school just a plane, train, and bus ride away in Kenya.

It was during these years in East Africa that Rodney started collecting world coins, garnered by his father who travelled extensively around the world as a fisheries scientist.

After returning by ship (the P&O liner Chusan) via Cape Town to England, he could not wait to leave again, and in 1978 with a young family in tow emigrated to New Zealand.

Along with his interest in NZ challenge coins, Rodney also collects NZ Geocoins, NZ Pathtags and Philippine challenge coins, and is actively researching and gathering data for future electronic catalogues.

Hamish MacMaster FRNSNZ



Hamish was born in 1961 in Christchurch, where he developed an early and passionate interest in coins and medals.

Hamish has been a member of the Royal Numismatic Society of NZ for over twenty-five years, serving as its Assistant Secretary (2003) and Secretary (2009-2013), and is currently a Vice President (2014-).

In addition to regular articles for the Society's Journal, he has written, in collaboration with Martin Purdy, the 2009 Catalogue of New Zealand Commemorative Medals 1941-2007, and its updated and expanded 2nd edition in 2014; and the 2011 New Zealand Challenge Coins: A Catalogue, and its second edition in 2016.

In 2010 he became a Fellow of the Society.

Pursuing a diplomatic career in the Ministry of Foreign Affairs and Trade, Hamish served as New Zealand's Ambassador to the Islamic Republic of Iran accredited also to Afghanistan and Pakistan (2004-2009) and was subsequently Ambassador to the Kingdom of Saudi Arabia (2015), resident in Riyadh and also accredited to Bahrain, Kuwait, and Oman. In 2016 his list of (non-resident) accreditations was expanded when he was appointed as New Zealand's first ever Ambassador to the Republic of Yemen. At the time of publication (2022), Hamish has recently returned from serving again as Ambassador to Iran.

Thematic Index

Aeroplane	1940/CEN/39
Arms/Shield	1940/CEN/2, 3, 4, 5, 6, 7, 8; 1939-40/EXH/2
Bird (other than kiwi)	1940/CEN/38
Building	1940/CEN/24, 25, 26, 27, 28, 43, 45, 45D; 1940/EXH/1, 7, 12, 13, 14
Celluloid badges	1940/CEN/45
Cook	1940/CEN/45H
Cross	1940/CEN/44, 46 (GLB logo)
Fern	1940/CEN/34
Golf clubs	1940/CEN/42
Horseshoe	1940/CEN/37
Kiwi	1940/CEN/15, 16, 17, 18, 19, 20, 21, 22, 23, 26, 37A, 37G, 41, 42, 45C; 1940/EXH/2, 3, 4, 5, 6, 8, 9, 10, 11, 17
Koruru	1940/CEN/45B
Māori figure (head, warrior)	1940/CEN/10, 11, 12, 13, 45F
Map	1940/CEN/9, 32, 45G; 1939-40/EXH/1
Nature	1940/CEN/31, 33
Photography	1940/EXH/7
Piper	1940/EXH/16
Ship/Waka	1940/CEN/1, 40, 41
Ship's wheel	1940/CEN/35
Then & Now	1940/CEN/1, 29, 30, 45A, 45E
Tiki	1940/CEN/14; 1940/EXH/15
Wishbone	1940/CEN/36; 1940/EXH/11, 17

Notes / New Additions



[1940/CEN/1.2]

ISBN 978-1-991161-20-8



9 781991 161208

